



# **α-PICO Datasheet**

## **UHF RFID Reader Module**



Dec. 2th, 2025  
Ver. 251202

AIoT  
UHF RFID Reader  
RF & Solution

DateCopyright(c)2024 by RFNSOL All righth reserved  
#540, Primabiztower, 24, Homaesil-ro, 90beon-gil, Gwonseon-gu,  
Suwon-si, Gyeonggi-do, Republic of Korea

# Table of Contents

Revision History.....	3
1. Introduction.....	4
2. Application.....	4
3. System Block Diagram.....	4
4. $\alpha$ -PICO Series .....	5
4.1 $\alpha$ -PICO Series.....	5
4.2 $\alpha$ -PICO Development Kit .....	5
5. Pin Definition.....	6
6. RFID Reader software .....	7
6.1 nSPACE .....	7
7. Electrical Specifications.....	8
7.1 Absolute Maximum Rating .....	8
7.2 Operating Conditions .....	8
7.3 Reader Radio Specifications.....	8
7.4 Reader Digital Interface Specifications.....	9
7.5 Reader physical Characteristics .....	9
8. Application Schematic .....	10
9. Package and Assembly Specifications.....	11
9.1 Dimensions .....	11
9.2 Footprint .....	13
10. Recommended Temperature Reflow Profile.....	14
11. Reliability and Environmental Specification .....	15
11. 1 Temperature test.....	15
11. 2 ESD Test .....	15
11. 3 Drop test .....	15
11. 4 Packaging information.....	15
12. Packaging Information .....	16
12. 1 Tray Specifications.....	16
12. 2 Outer box.....	16
Appendix A. Final Test Report.....	17
Appendix B. RFID Reader Frequency.....	18

# Revision History

Change	Date	Description
Ver251202	2025/12/02	Draft

RFNSOL

# 1. Introduction

The  $\alpha$ -PICO is an ultra-compact UHF RFID reader module that provides a complete solution using the ISO 18000-6C/EPC Gen2 protocol applications. It is particularly suitable for applications that require micro size, multi-tag support, medium read range, and low system cost.

With a 3dBic reader antenna, the recognition distance for passive tags is approximately 3 to 5 meters, and the maximum tag reading speed is more than 250 tags per second (@baudrate: 460.8 Kbps).

The  $\alpha$ -PICO features a Surface Mount Technology (SMT) package design, allowing it to be mounted directly onto a PCB without the need for additional connectors or hardware.

The  $\alpha$ -PICO is the optimal choice for small, low-cost embedded systems requiring UHF RFID reader functionality. This document includes details of the  $\alpha$ -PICO's interface, functionality, performance, mechanical characteristics, reliability test data, and packaging specifications.

# 2. Application

- Label / Mobile Printer
- Handheld / Mobile Readers
- USB Readers
- Tag Encoders

# 3. System Block Diagram

Figure 3-1 below shows the electrical connection specifications required to control the  $\alpha$ -PICO from the HOST for embedded applications.

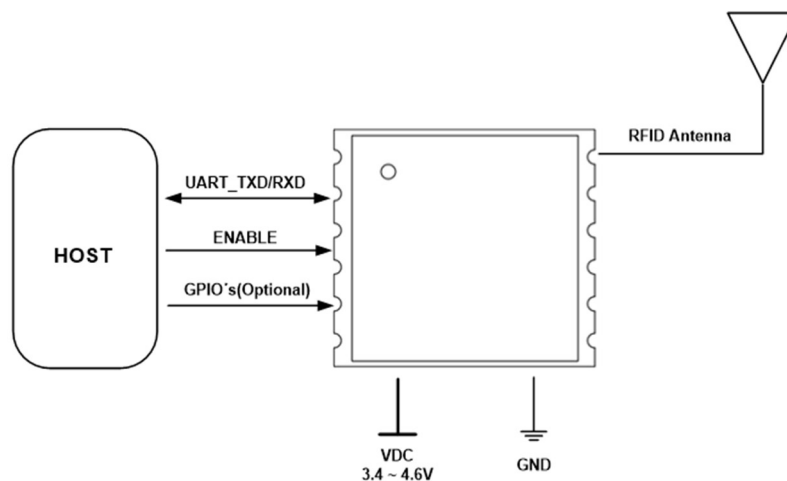

**Figure3-1 : SYSTEM Block Diagram**

- The  $\alpha$ -PICO requires a power supply VDC (typical: 4V) and GND.
- An Enable signal is required to enable or disable the  $\alpha$ -PICO power supply. If Enable is Low, the power supply is disabled; if Enable is High, the  $\alpha$ -PICO enters standby mode.
- The  $\alpha$ -PICO provides two user-controllable GPIOs (digital input/output).

## 4. α -PICO Series

This guide covers the α-PICO series of RFID readers as follows.

### 4.1 α -PICO Series

[ TABLE 4.1 ] α-PICO RFID Module

Part Number	Description
α-PICO-G100	Global Reader (KOREA, USA, ETSI Upper band...)
α-PICO-E200	ETSI Reader (Lower band)
α-PICO-J301	JAPAN (1W)
α-PICO-J302	JAPAN (250mW)

### 4.2 α -PICO Development Kit

[ TABLE 4.2 ] α-PICO Development Kit

Part Number	Description
α-PICO-KIT	α-PICO Module, Antenna, Interface Board, 12V/3A Adaptor, USB Cable

#### NOTE

If you require the product or Development Kit, please refer to the Part Number and request a purchase from your distributor.

## 5. Pin Definition

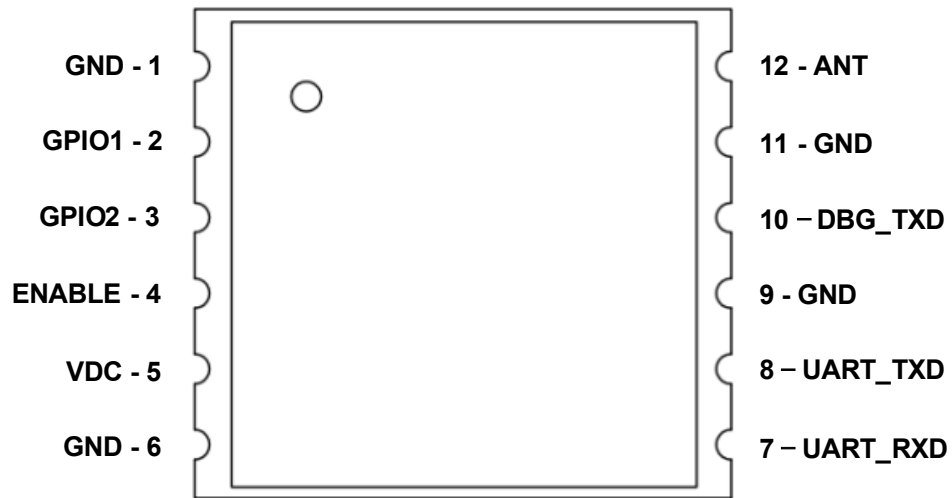

**Figure5-1 : Pin Diagram**

[ TABLE 5.1 ] Pin Descriptions

No.	Name	Type	Description
1	GND	Power	Ground
2	GPIO1	Digital I/O	General purpose I/O
3	GPIO2	Digital I/O	General purpose I/O
4	ENABLE	Digital Input	Module Enable, Active high
5	VDC	Power	DC voltage supply (3.4 ~ 4.6V)
6	GND	Power	Ground
7	UART_RXD	Digital Input	UART RX from host
8	UART_TXD	Digital output	UART TX to host
9	GND	Power	Ground
10	DBG_TXD	Digital output	Module Debug output
11	GND	Power	Ground
12	ANT	RF	SMT antenna port

## 6. RFID Reader software

The  $\alpha$ -PICO is provided together with the 'nSPACE' GUI Application, which allows you to verify its features and performance.

### 6.1 nSPACE

"nSPACE" is an RFID reader application that provides access to the RFID reader.

Using the  $\alpha$ -PICO-KIT, the RFID reader can be modified and controlled through a USB connection with the host PC.

This application offers the ability to configure communication and operational parameters of the RFID reader.

It also provides functions to read tags, review tag data, and perform diagnostics.

The application is intended for verifying the features and performance of the  $\alpha$ -PICO prior to product design.

For more details, please refer to the "nSPACE User Guide."

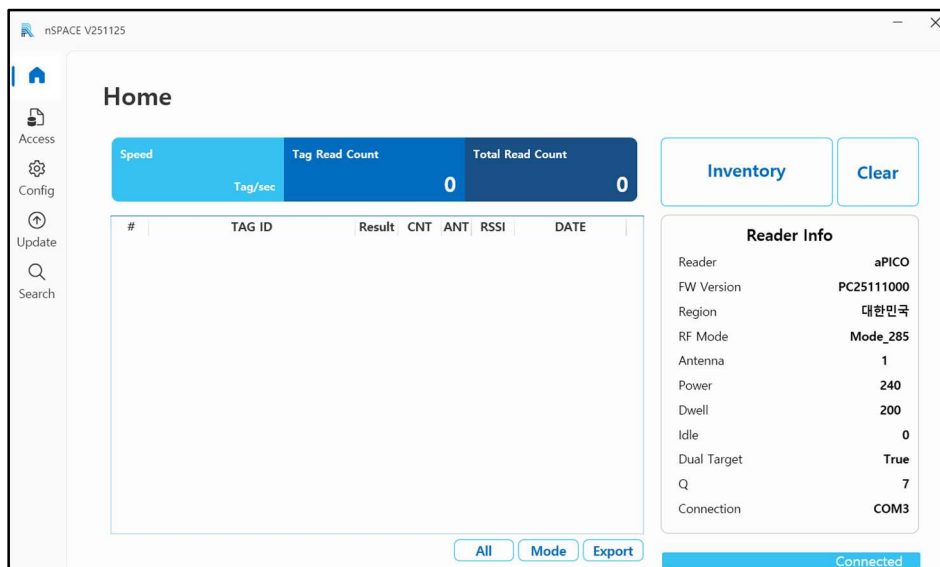

[ Figure 6.1 ] nSPACE GUI

## 7. Electrical Specifications

### 7.1 Absolute Maximum Rating

Stresses beyond those listed in Table 6-1 may cause permanent damage to the device. Exposure to absolute maximum rating conditions for extended periods may affect device reliability.

**Table 7-1 : Absolute Maximum Ratings**

Parameter	Min.	Max.	Unit	Comments
Supply voltage		4.6	V	
PWR_ENABLE		6	V	
IO Input voltage	-0.3	5.5	V	
Storage temperature	-30	+100	°C	
Humidity		95	%RH	
ESD immunity (Air discharge) (Contact discharge)		±8 ±4	kV kV	EN6100-4-2

### 7.2 Operating Conditions

**Table 7-2 : Operating Conditions**

Parameter	Min.	Max.	Unit	Conditions
Supply voltage (VCC)	3.4	4.2	V	Recommend voltage : 4V
Ambient Temperature	-20	+60	°C	
Inner Board Temperature	-20	+80	°C	<b>Note</b> : Prolonged use at high temperatures may cause product performance degradation and deterioration.

### 7.3 Reader Radio Specifications

VCC=4V, typical values at 25°C, unless otherwise noted.

**Table 7-3 : Reader Radio Specifications**

Parameter	Min.	Typ.	Max.	Unit	Conditions
Supply Current (Active mode)	370		950	mA	Transmit Power : +5 ~+30dBm
Supply Current (Standby mode)			30.4 10 50	mA mA nA	ENABLE : High ENABLE : Low Figure 8.2 requires an external circuit.
RX input impedance		50		Ω	
RX sensitivity		-74		dBm	
TX Power	+5		+30	dBm	
Frequency	860		930	MHz	See Appendix A
Channel bandwidth			200	kHz	
Channel Dwell time			0.4	Sec.	
Carrier sensing time	5			ms	Case in Japan
Carrier sensing level		-74		dBm	Case in Japan
Transmission time			4	Sec.	Case in Japan

## 7.4 Reader Digital Interface Specifications

VCC=4V, typical values at 25°C, unless otherwise noted.

**Table 5-4 : Reader Digital Interface Specifications**

Parameter	Min.	Typ.	Max.	Unit	Conditions
<b>PWR_ENABLE</b>					
VIH	1	3.3	5	V	
VIL	-0.3		0.4	V	
<b>GPIO</b>					
VIH	2.0	3.3	3.6	V	
VIL	-0.3		0.8	V	
<b>UART</b>					
Baud rate	9.6	460.8	921.6	kbaud	
Data bits		8		bit	
Parity		None			
Stop		1		bit	
Flow control		None			

## 7.5 Reader physical Characteristics

Parameter	Description
Dimensions	18mm(W) × 16.4mm(L) × 2.8mm(H)
Weight	1.5g
Housing Material	Aluminum

## 8. Application Schematic

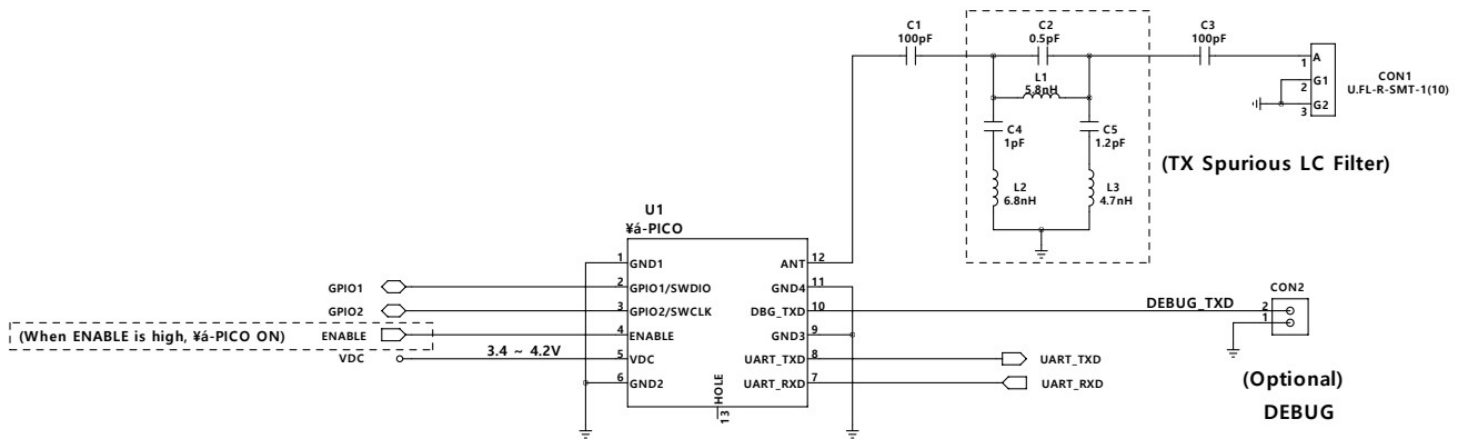

[ Figure 8.1 ] Application Schematic

COMPONENT VALUES			
Designator	Value	Description	Part number
U1	$\alpha$ -PICO	RFID_Module,2.5pitch,12pin,SMD	$\alpha$ -PICO
C1, C3	100pF	CAP,100pF,50V,5%,C0G,0402,SMD	
C2	0.5pF	CAP,0.5pF,0.05pF,COG,50V,0402,SMD	GJM1555C1HR50WB01D
C4	1pF	CAP,1pF,0.05pF,COG,50V,0402,SMD	GJM1555C1H1R0WB01D
C5	1.2pF	CAP,1.2pF,0.05pF,COG,50V,0402,SMD	GJM1555C1H1R2WB01D
L1	5.8nH	Coil IND,5.8nH,0.2nH,700mA,0402,SMD	LQW15AN5N8C00D
L2	6.8nH	Coil IND,6.8nH,2%,1.45A,0402,SMD	LQW15AN6N8G80D
L3	4.7nH	Coil IND,4.7nH,0.1nH,1.2A,0402,SMD	LQW15AN4N7B8ZD
CON1	U.FL-R-SMT-1	CON,Coaxial Micro-Plugs,4PIN,SMD	U.FL-R-SMT-1

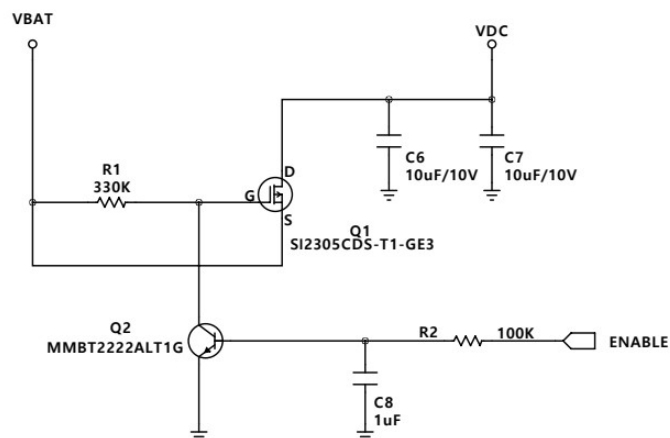

[ Figure 8.2 ] Power save Schematic

Figure 8.1 presents an example application circuit of the  $\alpha$ -PICO, with multiple configurations available depending on the user's application. Figure 8.2 shows a circuit designed for low-power consumption during standby mode. By controlling the Enable pin, the  $\alpha$ -PICO can achieve a standby current consumption of approximately  $\sim$ nA.

## 9. Package and Assembly Specifications

This section provides mechanical drawings and critical dimensions needed for PCB layout and SMT assembly information.

### 9.1 Dimensions

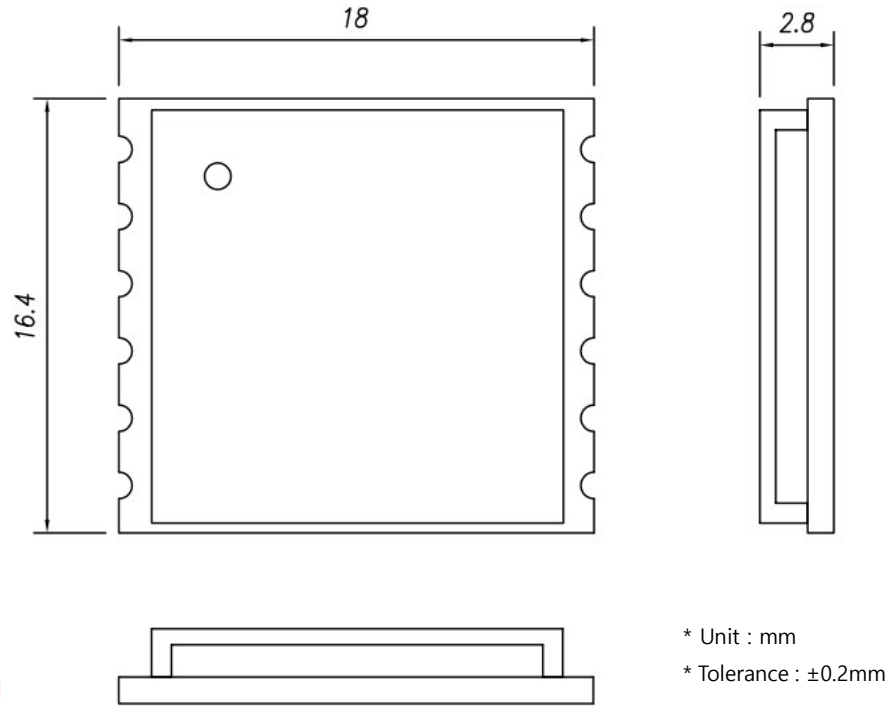

[ Figure 9.1 ]  $\alpha$ -PICO Package Dimensions (Top, Front, Side View)

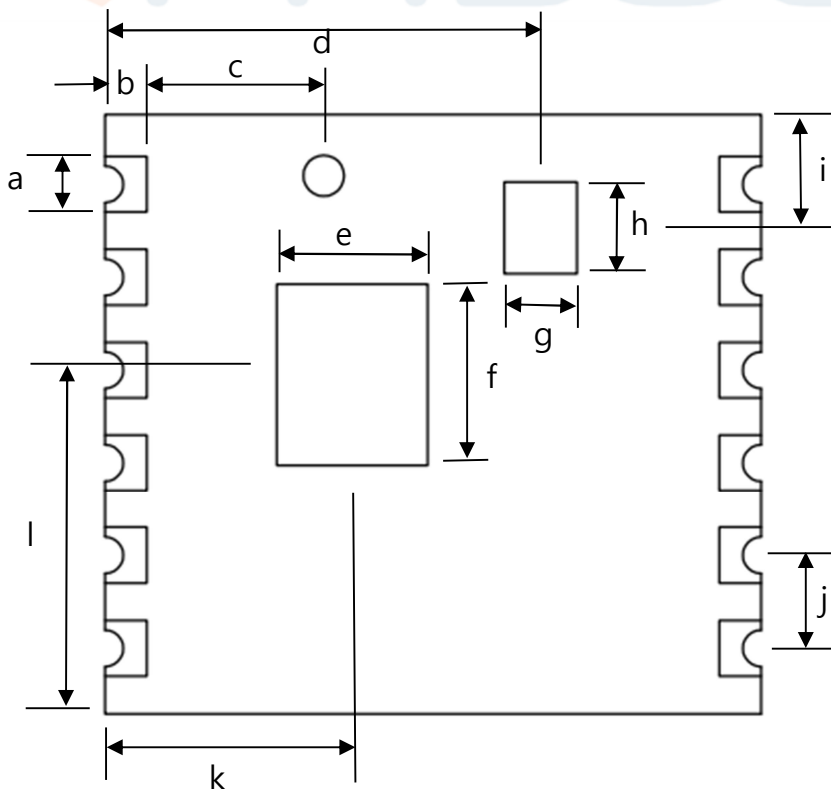

[ Figure 9.2 ]  $\alpha$ -PICO Package Pad Dimensions (Bottom View)

Dimensional Ref. (Unit : mm)			
REF.	Min.	Nom.	Max.
a		1.52	
b		1.15	
c		4.845	
d		11.95	
e		4.14	
f		4.96	
g		2	
h		2.5	
i		3.1	
j		2.54	
k		6.78	
l		9.28	

RFNSOL

## 9.2 Footprint

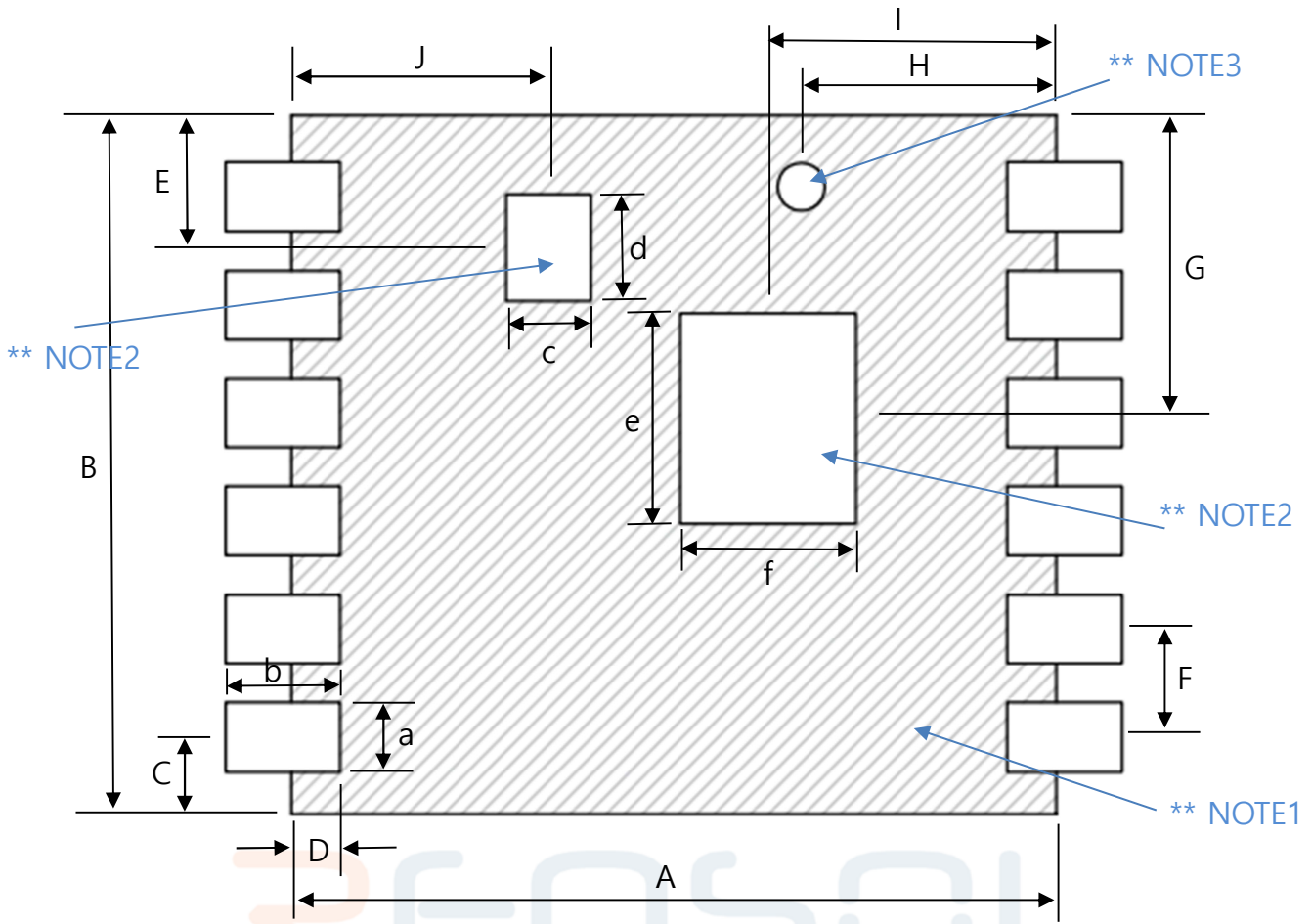

[ Figure 9.2 ]  $\alpha$ -PICO Package Footprint Dimensions

Dimensional Ref. (Unit : mm)							
REF.	Min.	Nom.	Max.	REF.	Min.	Nom.	Max.
A		18		a		1.62	
B		16.4		b		2.7	
C		1.79		c		2	
D		1.15		d		2.5	
E		3.1		e		4.96	
F		2.54		f		4.14	
G		7.12					
H		6					
I		6.78					
J		6.05					

**\*\*NOTE 1:** Do not place power or signal VIAs in the hatched area. If through VIAs must be used, print silkscreen on this area to prevent signal short issues at the bottom of the  $\alpha$ -PICO.

**\*\*NOTE 2:** The exposed paddle must be connected to GND.

**\*\*NOTE 3:** This area is the RF signal VIA region of the  $\alpha$ -PICO. It is recommended to apply Copper open or HOLE treatment across all layers.

# 10. Recommended Temperature Reflow Profile

The re-flow Profiles are illustrated in Figure 10.1

- Follow : IPC/JEDEC J-STD-020 C

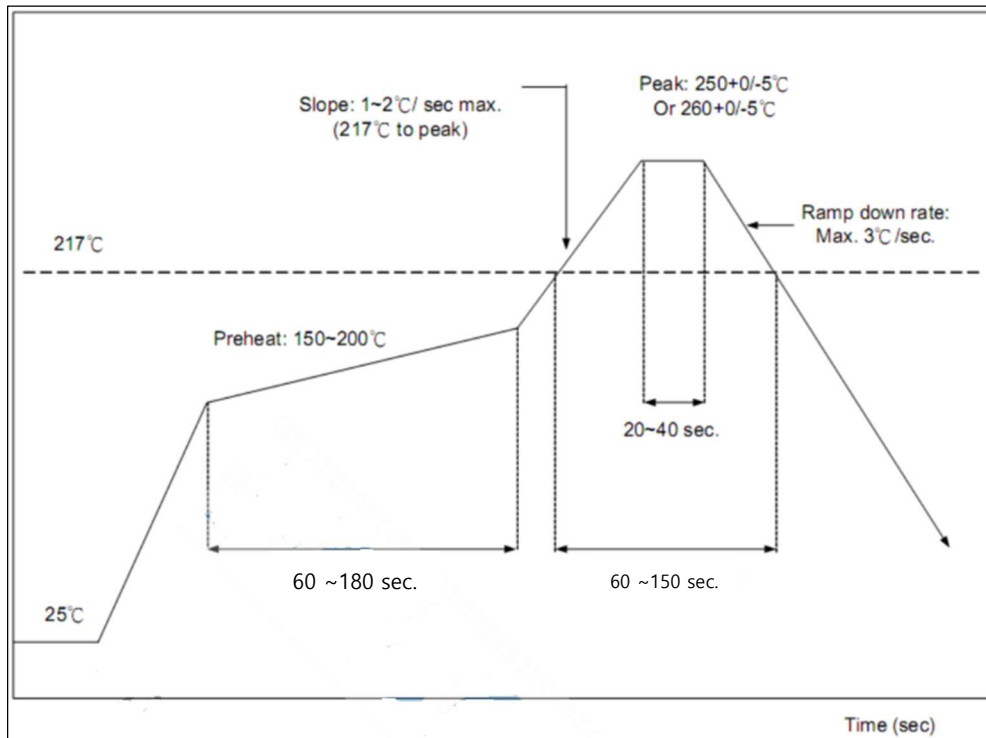

[ Figure 10.1 ] Typical Lead-free Re-flow Solder Profile

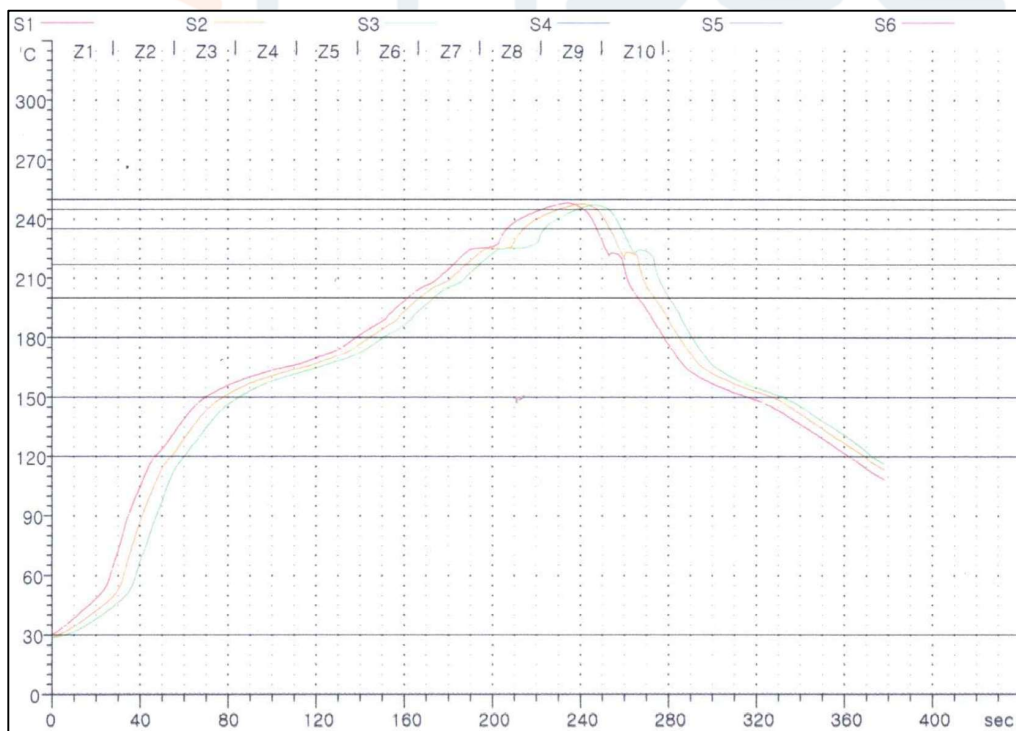

[ Figure 10.2 ] Typical Lead-free Re-flow

The soldering profile depends on various parameters according to the use of different solder and material.

The data here is given only for guidance on solder re-flow.

$\alpha$ -PICO will withstand up to two re-flows to a maximum temperature of 245°C.

# 11. Reliability and Environmental Specification

## 11. 1 Temperature test

Item	Detail Item	Test Condition	Test results
Storage Temp. test	High temperature	<ul style="list-style-type: none"> <li>- 3 samples, Power off</li> <li>- Temperature: 100 ±2°C</li> <li>- Test time : 48 hr</li> <li>- (2~24)hr at room temperature</li> </ul>	<ul style="list-style-type: none"> <li>- Check if it is operating normally</li> <li>- Check the change in tag recognition distance</li> </ul>
	Low temperature	<ul style="list-style-type: none"> <li>- 3 samples, Power off</li> <li>- Temperature: -30 ±2°C</li> <li>- Test time : 48 hr</li> <li>- (2~24)hr at room temperature</li> </ul>	<ul style="list-style-type: none"> <li>- Check if it is operating normally</li> <li>- Check the change in tag recognition distance</li> </ul>
Operating Temp. test	High temperature	<ul style="list-style-type: none"> <li>- 3 samples, Power on</li> <li>- Temperature: +60 ±2°C</li> <li>- Test time : 12 hr</li> <li>- Module : Dwell 200ms, Idle 0ms, Max.power(30dBm)</li> </ul>	<ul style="list-style-type: none"> <li>- Check if it is operating normally</li> <li>- Check the change in tag recognition distance</li> </ul>
	Low temperature	<ul style="list-style-type: none"> <li>- 3 samples, Power on</li> <li>- Temperature: -20 ±2°C</li> <li>- Test time : 12 hr</li> <li>- Module : Dwell 200ms, Idle 0ms, Max.power(30dBm)</li> </ul>	<ul style="list-style-type: none"> <li>- Check if it is operating normally</li> <li>- Check the change in tag recognition distance</li> </ul>
Thermal shock test		<ul style="list-style-type: none"> <li>- 3 samples, Power off</li> <li>- Temperature : +60°C/30min ⇔ -20°C/30min 1cycle</li> <li>- Test time : 12cycle</li> </ul>	<ul style="list-style-type: none"> <li>- Check if it is operating normally</li> <li>- Check the change in tag recognition distance</li> </ul>

## 11. 2 ESD Test

Item	Test Condition	Test results
ESD TEST	<ul style="list-style-type: none"> <li>- 1 samples, Power on</li> <li>- Human Body model : standard ±4kV(contact), ±8kV(air) (R1=10 MΩ, R2=1.5 kΩ, C=150pF)</li> </ul>	<ul style="list-style-type: none"> <li>- Check if it is operating normally</li> <li>- Check the change in tag recognition distance</li> </ul>

## 11. 3 Drop test

Free fall the module (condition built in a wrapper which can defend ESD) from 150cm height to cement ground, each side twice, total twelve times. The appearance will not be damaged and all functions OK.

## 11. 4 Packaging information

After unpacking, the module should be stored in environment as follows:

Temperature : 25°C ± 2°C

Humidity : <60%

No acidity, sulfur or chlorine environment

The module must be used in seven days after unpacking.

## 12. Packaging Information

The  $\alpha$ -PICO shipping package is composed of anti-static trays and an outer carton, each accommodating up to 250 units.

### 12. 1 Tray Specifications

The tray, which accommodates up to 25  $\alpha$ -PICO units, has approximate dimensions of width mm  $\times$  length mm  $\times$  height mm. It is designed to prevent product interference and to shield against external electrostatic discharge.

### 12. 2 Outer box

The outer box is made of printed cardboard, which protects against dust, moisture, and impact, and facilitates transportation. The dimensions of the outer box are approximately 330 mm in width, 245 mm in length, and 84 mm in height.

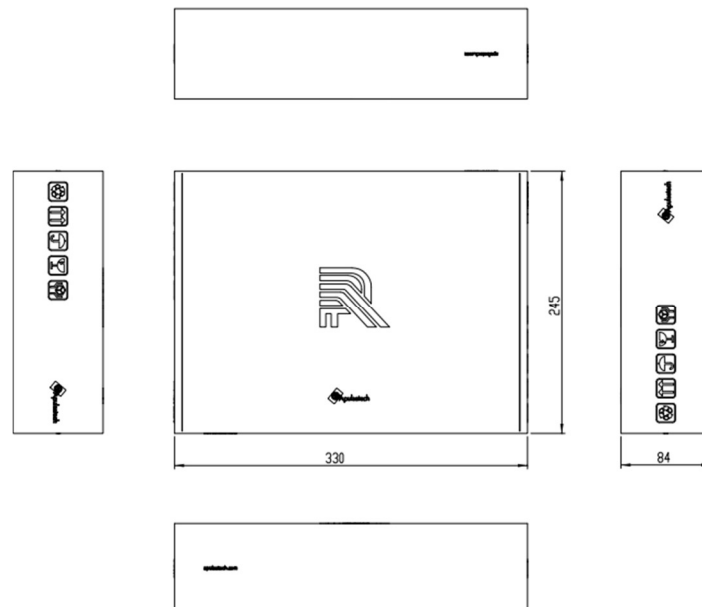



# Appendix B. RFID Reader Frequency

This chapter provides information on the channels and frequencies of the  $\alpha$ -PICO RFID Reader.

[단위 : KHz]

	South Korea (KOR)	FCC	China (CHN)	Hong Kong (HKG)	Singapore (SGP)	Taiwan (TWN)	Vietnam (VNM)	Japan FHSS	ETSI Lower
1	917300	902750	920625	920750	920750	920750	918750	916800	865700
2	917900	903250	920875	921250	921250	921250	919250	918000	866300
3	918500	903750	921125	921750	921750	921750	919750	919200	866900
4	919100	904250	921375	922250	922250		920250	920400	867500
5	919700	904750	921625	922750	922750		920750		
6	920300	905250	921875	923250	923250		921250		
7		905750	922125	923750	923750		921750		
8		906250	922375	924250	924250		922250		
9		906750	922625						
10		907250	922875						
11		907750	923125						
12		908250	923375						
13		908750	923625						
14		909250	923875						
15		909750	924125						
16		910250	924375						
17		910750							
18		911250							
19		911750							
20		912250							
21		912750							
22		913250							
23		913750							
24		914250							
25		914750							
26		915250							
27		915750							
28		916250							
29		916750							
30		917250							
31		917750							
32		918250							
33		918750							
34		919250							
35		919750							
36		920250							
37		920750							
38		921250							
39		921750							
40		922250							
41		922750							
42		923250							
43		923750							
44		924250							
45		924750							
46		925250							
47		925750							
48		926250							
49		926750							
50		927250							

# RFNSOL

# RFNSOL

AIoT

UHF RFID Reader

RF & Solution

DateCopyright(c)2024 by RFNSOL All righth reserved

#540, Primabiztower, 24, Homaesil-ro, 90beon-gil, Gwonseon-gu, Suwon-si, Gyeonggi-do, Korea

RFNSOL Co.,Ltd [www.rfnsol.com](http://www.rfnsol.com)